

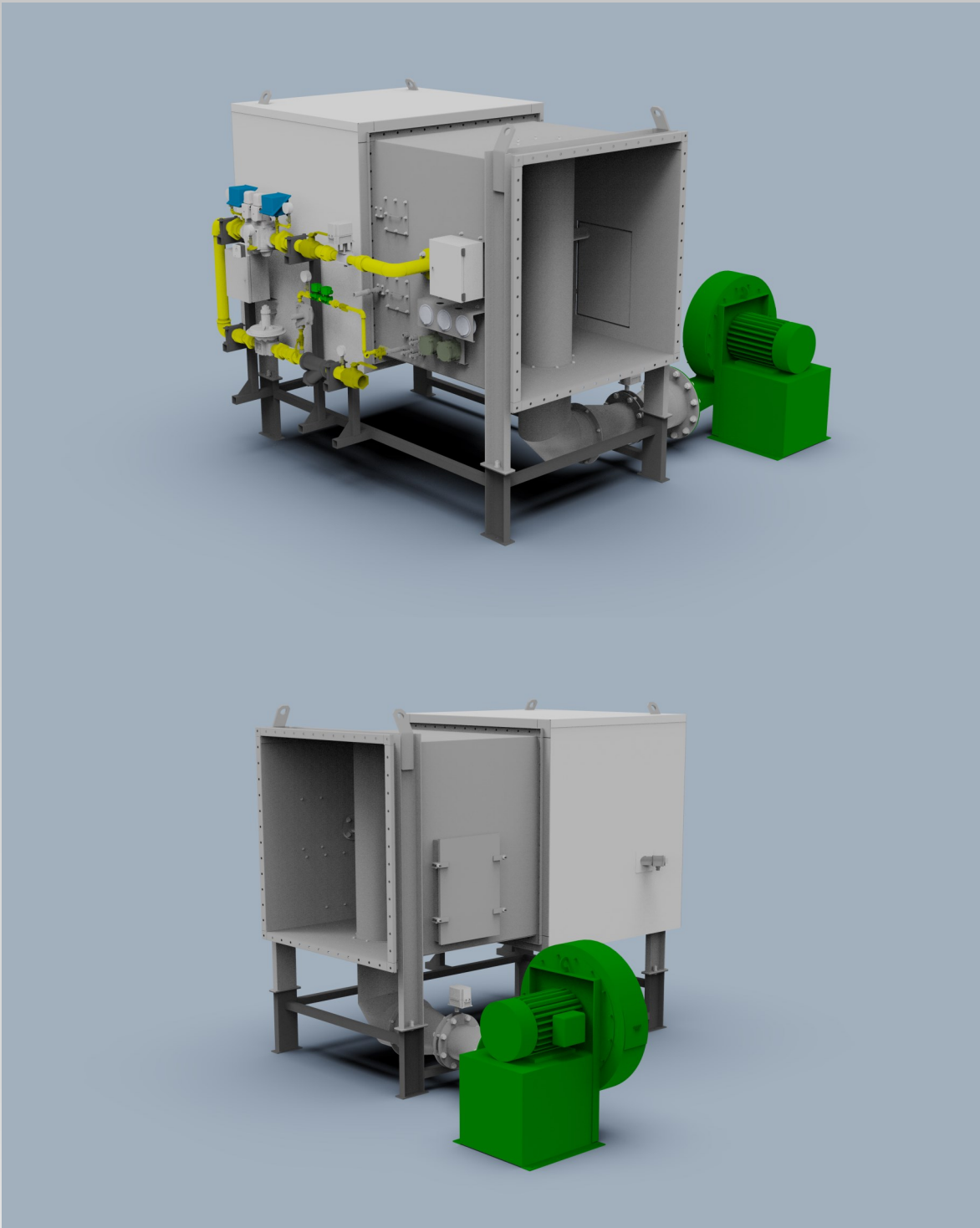

STAR/HEATER TYPE R

**LOW NO_x INDUSTRIAL PROCESS AIR HEATER FOR
FRESH OR RE-CIRCULATED AIR STREAM
TECHNICAL GUIDE**



STAR/HEATER

TYPE R LOW NO_x DIRECT FIRED PROCESS AIR HEATERS

The Star|Heater type R is a duct style process air heater for fresh or re-circulated air. It provides low or high temperature air to drying, baking, and curing processes. This packaged heater system comes in two pieces: the inlet section housing the burner and fuel train, and the outlet section to contain the flame. This heater system optionally comes with a burner management control system to provide flame safety, fault annunciation, and single or multi-loop PID temperature control. The Star|Heater has 28 standard burner configurations ranging from 500,000 btu/hr to 62,500,000+ btu/hr. Burners are sized to fit the application, not the other way around.

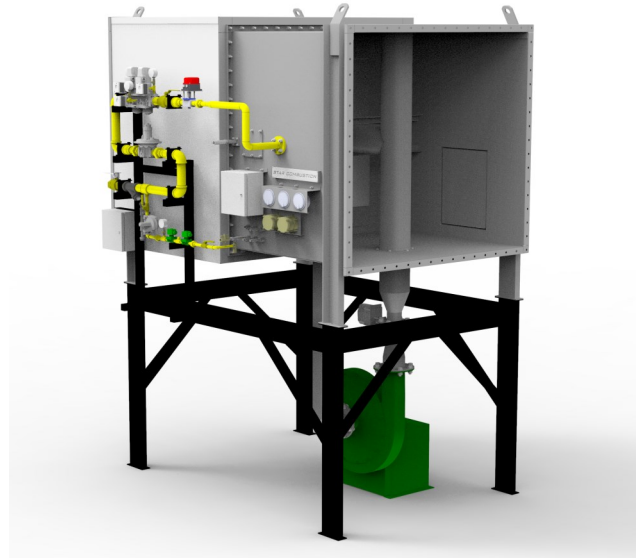

QUALITY



- * Quality construction using robust 10 gauge mild or stainless steel for long lasting service
- * High strength support legs with slotted mounting feet to allow for thermal expansion of heater body. Optional wheels are available for the supports on HTX outlet sections running close to maximum rated temperatures
- * Weatherproof design to allow for outdoor or indoor installation
- * A full set of adjustable profile plates are included with each heater to allow for field adjustments to changes in process air flow
- * 800°F heat resistant coating provided on all mild steel components
- * 4" thick mineral wool insulation with 22 gauge galvanized insulation skin is provided on heater section. The insulation and skin is designed to allow for thermal expansion and watershed
- * Sight port included for visual inspection of the spark, pilot flame and main flame to allow for easy maintenance and commissioning
- * Welded main gas and combustion air headers are generously sized to provide proper gas distribution and temperature uniformity
- * 6000 volt full wave ignition transformer is mounted inside weatherproof enclosure to provide protection and long service life
- * Pressure taps to measure upstream process air, downstream process air, differential combustion air, and differential gas pressure provided to allow for ease of maintenance and commissioning
- * Included process air pressure switch measures differential pressure across the burner to prove sufficient air flow

PERFORMANCE

- * 20:1 burner turndown allows for application flexibility
- * 13 standard sizes ranging from 18" diameter round to 90" square
- * Standard process air flow capability up to 84,300 standard ft³/min (scfm) and beyond
- * Outlet temperatures to 1500°F and beyond allow for more efficient drying capability in certain applications
- * Duct static pressure capability to 28"wc and beyond make the Star|Heater perfectly suited for fluidized bed drying applications
- * Inlet air temperatures to 650°F and beyond allow for heat recovery to be used, providing lower operating costs



Front of **STAR/HEATER**[®]

VALUE

- * The low NO_x direct fired burner requires a combustion air fan for proper combustion in low O₂ and high moisture re-circulated air streams.
- * Inlet or outlet section can be inter-changed in the field without replacing the entire heater
- * Lifting lugs to allow for ease of installation and maintenance
- * Quick open man way access hatch included to allow for easy service and adjustment of burner and profile plates
- * Externally mounted flame sensors to provide easy service and inspection
- * Small side access hatch to allow service of spark igniter and related cabling without entering the heater
- * Compact design allows for total heater lengths less than 108"

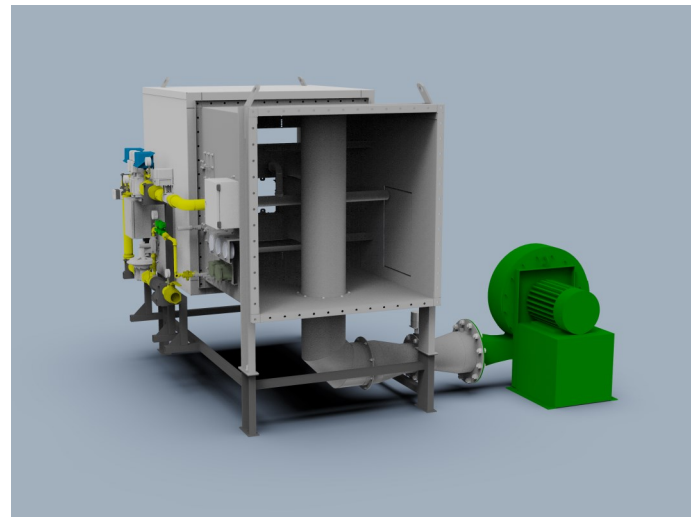

Back of **STAR/HEATER**[®]

STAR/HEATER INLET SECTION CONSTRUCTION

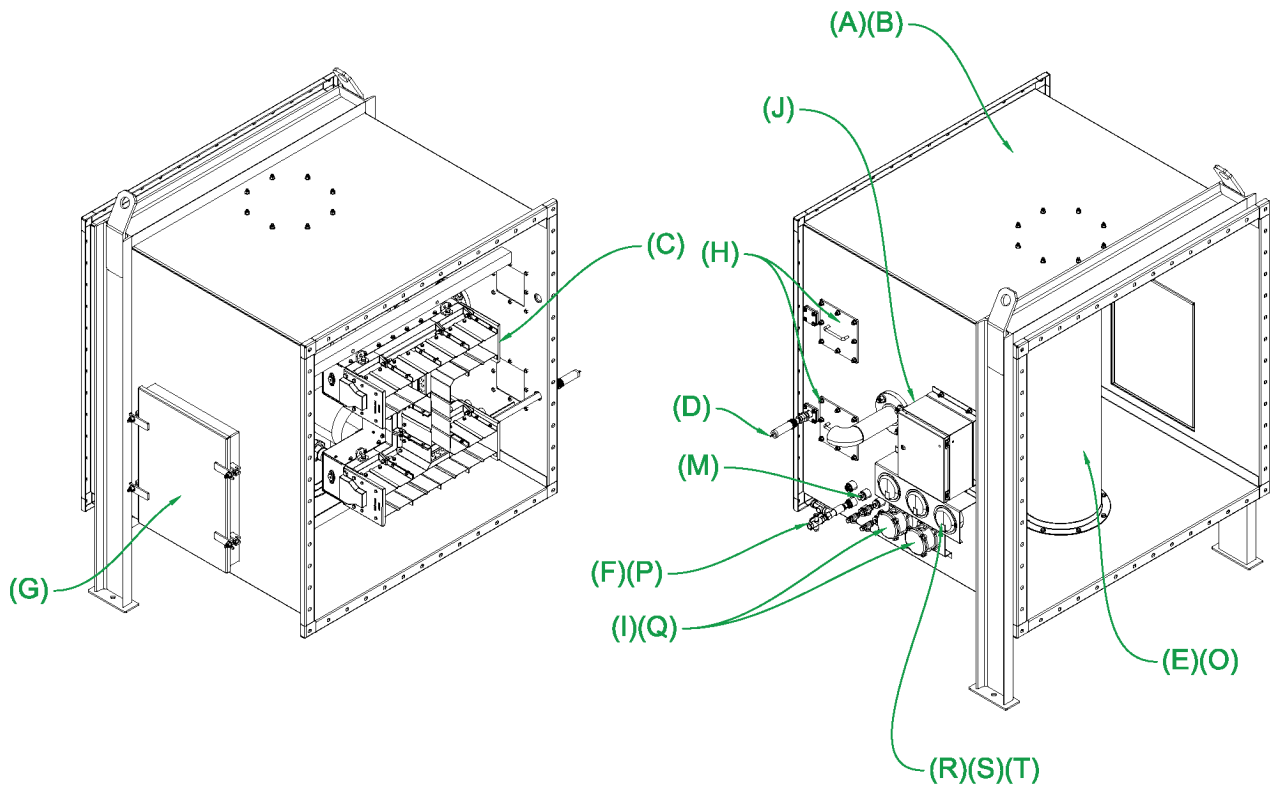

INCLUDED COMPONENTS:

- (A) 10 gauge construction in mild, 304 stainless, or 316 stainless steel with inlet flange
- (B) Mild steel construction is coated with a robust 800°F heat resistant coating
- (C) Low NOx, duct style burner configured to fit the heater size including spark igniter, flame sensor, and pilot
- (D) UV scanner. On size 100 and larger burners, dual flame sensors are used to prove flame propagation. When using UV scanners on heaters that are used more than 24hr/day, self check type is used
- (E) Main gas distribution header, welded/flanged
- (F) Pilot gas adjusting orifice
- (G) 24" x 18" access hatch to inspect and adjust burner and profile plates
- (H) 6" x 6" access hatch(s) to inspect and replace spark igniter and flame sensors from the outside
- (I) Process air pressure switch to prove process air flow across the burner
- (J) 6000v full wave ignition transformer mounted inside NEMA 4 enclosure including duct feed through insulator and ignition cable/terminations
- (M) Test ports to monitor process air pressure as well as main gas pressure
- (O) Combustion air distribution header, welded/flanged
- (P) Pilot air/gas mixer with pilot combustion air adjusting orifice
- (Q) Combustion air pressure switch to prove combustion air fan is operating
- (R)(S)(T) Differential pressure gauges for process air, combustion air, and gas

A fuel train to meet all standards within North America including NFPA 86, Factory Mutual, CSA, and GE-GAP/IRI is also normally included. Option available to meet EN-746/CE and Australian Gas Assoc standards

STAR/HEATER FUEL TRAIN CONSTRUCTION

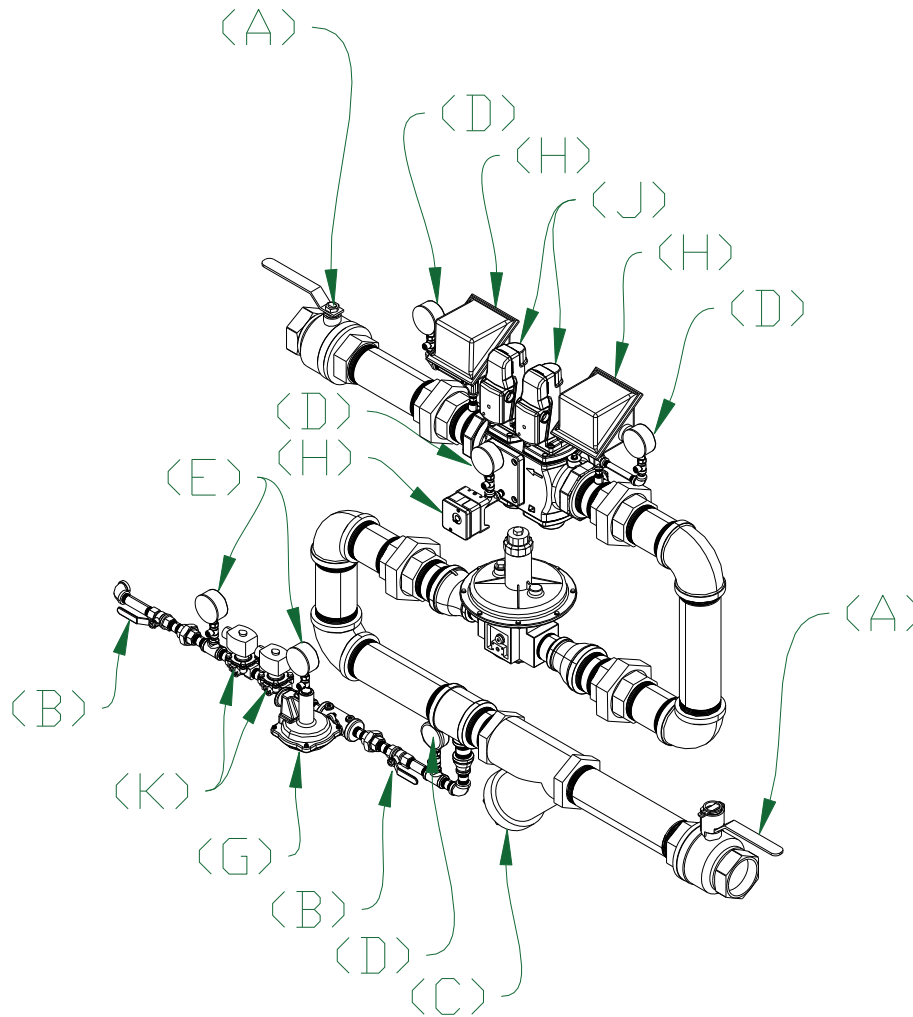

INCLUDED COMPONENTS:

- (A) Inlet and outlet ball valve
- (B) Inlet and outlet pilot ball valve
- (C) Inlet gas filter
- (D) Inlet, regulator, leak test, and outlet pressure gauge with isolation cock
- (E) Pilot regulator and pilot outlet pressure gauge with isolation cock
- (F) Main gas regulator
- (G) Pilot gas regulator
- (H) Low and high gas pressure switches
- (I) Valve proving pressure switch
- (J) Dual main gas shut off valves with visual indication and proof of closure switch
- (K) Dual pilot gas solenoid valves

STAR/HEATER OUTLET SECTION CONSTRUCTION

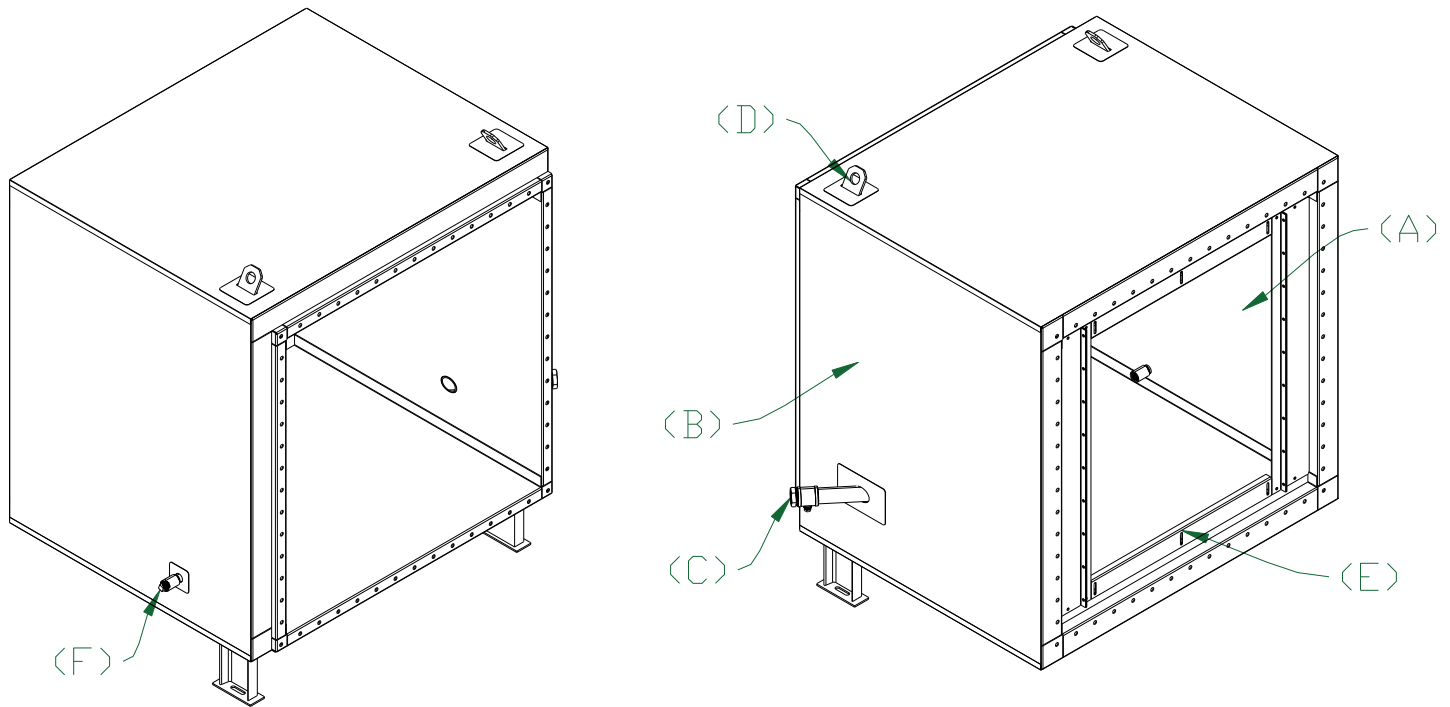

INCLUDED COMPONENTS:

- (A) 10 gauge construction in mild, 304 stainless, or 321 stainless steel with full dimension outlet flange, square to round, or square to square reducer sections
- (B) 4" mineral wool insulation clad with .032" thick galvanized steel on STD and HTS heater sections, 6" internal refractory insulation on HTR heater section. When external insulation is applied, the heater "free floats" under the insulation skin, allowing the heater to expand and contract as normal without distorting the insulation
- (C) Sight port to allow clear view of spark, pilot, and main flame
- (D) Lifting lugs provided to for ease of installation
- (E) Adjustable burner profile plates to provide proper pressure drop and flow conditioning for duct burner
- (F) Pressure sensing port to sense pressure downstream of profile plate

STAR/HEATER OUTLET SECTION CONSTRUCTION

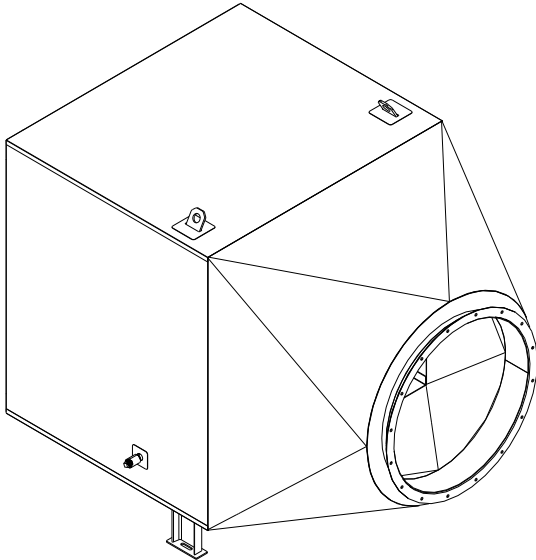

**SQUARE TO ROUND REDUCED
OUTLET OPTION**

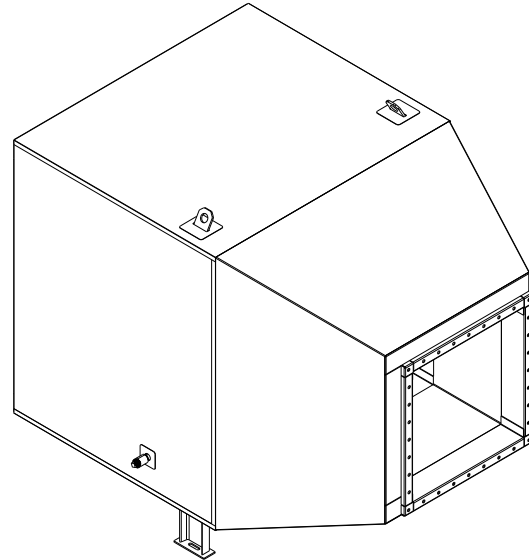

**SQUARE TO SQUARE REDUCED
OUTLET OPTION**

TYPE R STARHEATER AVAILABLE OPTIONS:

- * Square to round reduced outlet transition section with connecting flange
- * Square to square reduced outlet transition section with connecting flange
- * Square to rectangle reduced outlet transition section with connecting flange
- * Other options available for heater outlet connections
- * Custom options available for insulation cladding, including stainless steel
- * Custom stands available to raise heater centerline to match dryer inlet
- * Flex connections available for process duct or dryer connection
- * Perforated plates available to evenly distribute process air prior to burner
- * Process air fans and fan to heater ductwork available to meet any application

STAR/HEATER CAPACITIES AND SPECIFICATIONS

Heater Specifications

Heater Size	Heater Outside Dimensions L x W (inches)	Nominal Air Flow Capacity (scfm) at normal velocity	Maximum Air Flow Capacity (scfm) at maximum velocity	Maximum Burner Size	Maximum Burner Capacity (btu/hr)
18	18 diameter	1,770	2,650	010	1,250,000
26	26 x 26	4,700	7,050	020	2,000,000
30	30 x 30	6,250	9,380	040	5,000,000
38	38 x 38	10,030	15,050	060	8,750,000
42	42 x 42	12,250	18,380	080	11,250,000
50	50 x 50	17,370	26,050	120	16,875,000
54	54 x 54	20,250	30,380	150	18,750,000
62	62 x 62	26,700	40,050	200	22,000,000
66	66 x 66	30,250	45,380	220	27,500,000
74	74 x 74	38,030	57,050	300	32,500,000
78	78 x 78	42,250	63,380	350	40,625,000
86	86 x 86	51,370	77,050	420	52,500,000
90	90 x 90	56,250	84,380	500	62,500,000

Inlet Section Specifications

	ST Inlet Section	HT Inlet Section
Maximum Inlet Temperature	250°F	500°F
Minimum Oxygen Content of Process Air	4.0%	4.0%
Minimum Air Velocity Across Burner (reduced max cap)	800 ft/min (0.05"wc DP)	800 ft/min (0.05"wc DP)
Maximum Air Velocity Across Burner	5000 ft/min (2.1"wc DP)	5000 ft/min (2.1"wc DP)
Materials of Construction	Mild Steel	304 Stainless Steel
Differential Gas Pressure, Natural Gas 2mm btuh/ft	29.4"wc	29.4"wc
Differential Gas Pressure, Natural Gas 2.5mm btuh/ft	46.0"wc	46.0"wc
Differential Gas Pressure, Propane Gas 2mm btuh/ft	11.7"wc	11.7"wc
Differential Gas Pressure Propane Gas 2.5mm btuh/ft	18.4"wc	18.4"wc
Differential Combustion Air Pressure, 2mm btuh/ft	8.3"wc	8.3"wc
Differential Combustion Air Pressure, 2.5mm btuh/ft	13.0"wc	13.0"wc
Minimum Supply Pressure to Fuel Train Inlet	5 psig	5 psig
Maximum Supply Pressure to Fuel Train Inlet	10 psig	10 psig

Outlet Section Specifications

	STX Outlet Section	HTX Outlet Section	HTR Outlet Section
Maximum Outlet Temperature	650°F	1000°F	1500°F
Insulation Type	External Mineral Wool	External Mineral Wool	Internal Refractory
Materials of Construction	Mild Steel	321 Stainless Steel	Mild Steel
Air Pressure Drop Through Heater at Max Air Flow	<2.0"wc	<2.0"wc	<2.0"wc
Expected NO _x	<25 ppm at 3% O ₂	<25 ppm at 3% O ₂	<25 ppm at 3% O ₂
Expected CO	<250 ppm at 3% O ₂	<200 ppm at 3% O ₂	<150 ppm at 3% O ₂

STAR/HEATER CAPACITIES AND SPECIFICATIONS

Burner Size	Burner Capacity at 2mm btuh/ft (btu/hr, HHV)	Burner Capacity at 2.5mm btuh/ft (btu/hr, HHV)	Minimum Burner Capacity (btu/hr, HHV)	Fuel Train Inlet Size	Combustion Air Inlet Size
010	1,000,000	1,250,000	50,000	1" NPT	8"
020	2,000,000	2,500,000	60,000	1-1/2" NPT	8"
030	3,000,000	3,750,000	150,000	1-1/2" NPT	8"
040	4,000,000	5,000,000	200,000	1-1/2" NPT	8"
060	6,000,000	7,500,000	300,000	1-1/2" NPT	8"
080	8,000,000	10,000,000	400,000	2" NPT	8"
100	10,200,000	12,750,000	510,000	2-1/2" NPT	12"
120	12,200,000	15,250,000	610,000	2-1/2" NPT	12"
150	15,200,000	19,000,000	760,000	3" NPT	14"
180	18,200,000	22,750,000	910,000	3" NPT	12"
200	20,200,000	25,250,000	1,100,000	3" NPT	14"
250	26,400,000	32,500,000	1,320,000	3" NPT	(2) 14"
300	30,400,000	38,000,000	1,500,000	3" NPT	(2) 14"
350	35,600,000	44,500,000	1,780,000	3" flanged	(2) 14"
420	42,800,000	52,500,000	2,120,000	3" flanged	(2) 16"
450	44,800,000	56,000,000	2,240,000	4" flanged	(2) 16"
500	50,800,000	63,500,000	2,540,000	4" flanged	(2) 16"

Capacities air based on 0.65 specific gravity natural gas with 1050 btu/ft³ higher heating value.

Flame will be completely contained within the heater when profile plates are adjusted with a minimum of 0.5"wc profile. plate pressure drop

STAR/HEATER MODEL NUMBER INTERPERETATION

StarHeater Type R TABLE (I) - TABLE (II) - TABLE (III) - TABLE (IV) - (TABLE V) - (TABLE VI) - (TABLE VII) - (TABLE VIII)

Example: StarHeater Type R54-NG-ST-HTX-DR-150-R-T

TABLE I — Heater Size

Heater Size	Dimensions	SCFM nominal	SCFM maximum	Max Burner Size
18	18" OD ROUND	1,765	2,650	010
26	26" x 26" OD	4,700	7,050	020
30	30" x 30" OD	6,250	9,380	040
38	38" x 38" OD	10,030	15,050	060
42	42" x 42" OD	12,250	18,380	080
50	50" x 50" OD	17,375	26,050	120
54	54" x 54" OD	20,250	30,380	150
62	62" x 62" OD	26,700	40,050	200
66	66" x 66" OD	30,250	45,380	220
74	74" x 74" OD	38,030	57,050	300
78	78" x 78" OD	42,250	63,380	350
86	86" x 86" OD	51,360	77,050	420
90	90" x 90" OD	56,250	84,380	500

TABLE II—Fuel Type

Abbreviation	Definition
NG	Natural Gas
PG	Propane Gas
BG	Mixed Gas with Butane
DG	Dual Natural and Propane Gas

TABLE III—Burner Section Type

Abbreviation	Definition
ST	Mild Steel (< 250°F inlet temp)
HT	304 Stainless Steel (< 500°F inlet temp)

TABLE IV—Heater Section Type

Abbreviation	Definition
STX	Standard design, external insulation (< 650°F outlet temp)
HTX	High temp design, external insulation (< 1000°F outlet temp)
HTR	High temp design, internal insulation (< 1500°F outlet temp)

TABLE V—Fuel Train Mounting

Abbreviation	Definition
DR	Fuel train mounted directly on right side of heater
DL	Fuel train mounted directly on left side of heater
RR	Fuel train remote mounted, inlet on right side of heater
RL	Fuel train remote mounted, inlet on left side of heater

TABLE VI — Burner Size

Burner Size	Nominal Burner Capacity (BTU/hr, HHV)	Maximum Burner Capacity (BTU/hr, HHV)
010	1,000,000	1,250,000
020	2,000,000	2,500,000
030	3,000,000	3,750,000
040	4,000,000	5,000,000
060	6,000,000	7,500,000
080	8,000,000	10,000,000
100	10,200,000	12,750,000
120	12,200,000	15,250,000
150	15,200,000	19,000,000
180	18,200,000	22,750,000
200	20,200,000	25,250,000
250	26,400,000	32,500,000
300	30,400,000	38,000,000
350	35,600,000	44,500,000
420	42,800,000	52,500,000
450	44,800,000	56,000,000
500	50,800,000	63,500,000

TABLE VII - Outlet Transition Type

Abbreviation	Definition
F	Full dimension flanged outlet
R	Square to round transition outlet with flange
S	Square to square/rectangle transition outlet with flange
X	Special dimension outlet

TABLE VIII - Combustion Air Inlet

Abbreviation	Definition
T	Combustion air inlet from top of heater
B	Combustion air inlet from bottom of heater
X	Special combustion air inlet arrangement

STAR/HEATER WITH OUTLET OPTION F DIMENSIONS

ALL DIMENSIONS IN INCHES UNLESS OTHERWISE NOTED

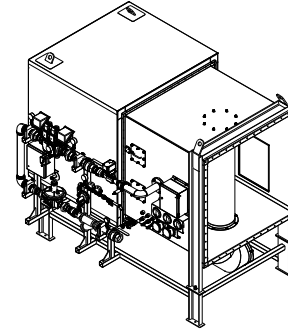
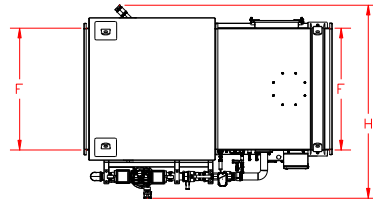
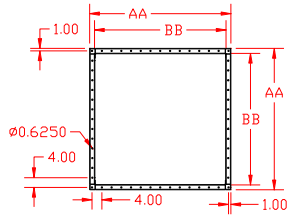

INLET / OUTLET FLANGE

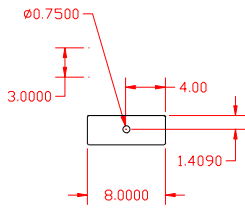
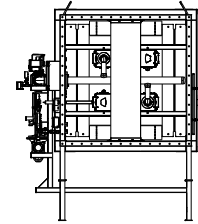
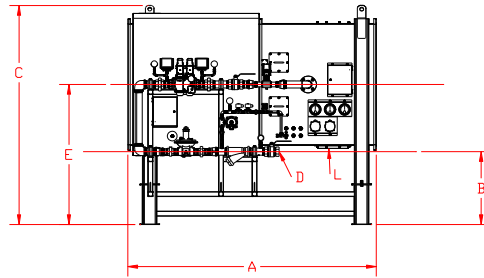

SCALE 4:1

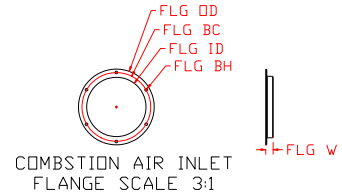
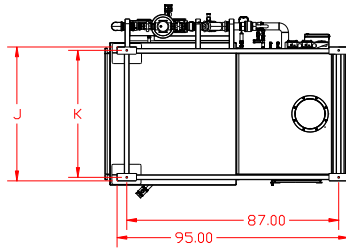

	A	B	C	D	E	F	G	H	
1	SUPPLIED COMBUSTION AIR INLET FLANGE DIMENSIONS								
2	INLET SIZE	FLG DD	FLG BC	FLG ID	FLG BH	# HOLES	FLG W	MAT	
3	8"	10.375"	9.4375"	8.125"	0.375"	6	1"	10ga	
4	12"	15.125"	14"	12.125"	0.4375"	8	1.5"	10ga	
5	14"	17.125"	16"	14.125"	0.4375"	8	1.5"	10ga	
6	16"	19.125"	18"	16.125"	0.4375"	8	1.5"	0.1875"	

FOOT PLATE

Heater Size	A	B	C	D,L	E	F	H	J	K	AA	BB
26	102	35	53.5	See page 9	26	26	65	30.92	28.105	30	26
30	102	37	57.5	See page 9	30	30	69	34.92	32.105	34	30
38	102	41	65.5	See page 9	38	38	77	42.92	40.105	42	38
42	102	43	69.5	See page 9	42	42	81	46.92	44.105	46	42
50	102	47	77.5	See page 9	50	50	89	54.92	52.105	54	50
54	102	49	81.5	See page 9	54	54	93	58.92	56.105	58	54
62	102	53	89.5	See page 9	62	62	101	66.92	64.105	66	62
66	102	55	93.5	See page 9	66	66	105	70.92	68.105	70	66
74	102	59	101.5	See page 9	74	74	113	78.92	76.105	78	74
78	102	61	105.5	See page 9	78	78	117	82.92	80.105	82	78
86	102	65	113.5	See page 9	86	86	125	90.92	88.105	90	86
90	102	67	117.5	See page 9	90	90	129	94.92	92.105	94	90

STAR/HEATER WITH OUTLET OPTION R DIMENSIONS

ALL DIMENSIONS IN INCHES UNLESS OTHERWISE NOTED

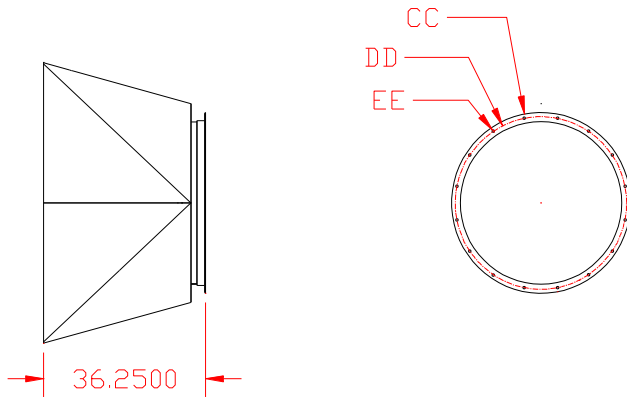

OUTLET FLANGE

Heater Size	CC	DD	EE
26	20.125	20	8 - 0.5"
30	23.125	21.75	12 - 0.5"
38	23.125	21.75	12 - 0.5"
42	32.125	30.375	16 - 0.5"
50	38.125	36.375	16 - 0.5"
54	40.125	38.375	16 - 0.5"
62	46.125	44.375	24 - 0.5"
66	48.125	46.375	24 - 0.5"
74	54.125	52.375	24 - 0.5"
78	56.125	54.375	24 - 0.5"
86	62.125	60.375	24 - 0.5"
90	64.125	62.375	24 - 0.5"

ADD TO DIMENSION A ON PAGE 11

STAR/HEATER WITH OUTLET OPTION S DIMENSIONS

ALL DIMENSIONS IN INCHES UNLESS OTHERWISE NOTED

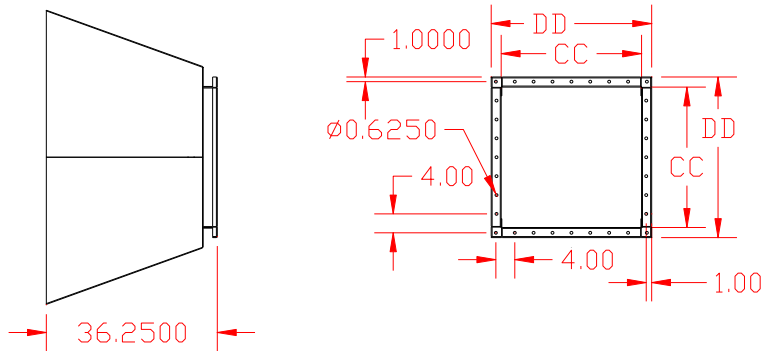

OUTLET FLANGE

Heater Size	CC	DD
26	16	20
30	18	22
38	22	26
42	24	28
50	30	34
54	30	34
62	36	40
66	40	44
74	44	48
78	46	50
86	50	54
90	54	58

ADD TO DIMENSION A ON PAGE 11

STAR/HEATER INSTALLATION INSTRUCTIONS

Please read all installation and commissioning instructions before proceeding with installation.

*** IMPORTANT ***

Installation and commissioning should only be done by properly trained and qualified personnel. Failure to do so can result in significant property damage, and injury or death to personnel. Follow all applicable piping and gas safety codes when installing and commissioning this system.

The type R Star|Heater is an integral part of an industrial drying, curing, or heating process. System fans, burner management, temperature controls, high temperature limit, and corresponding ductwork must be supplied to compete the heating system for the drying, curing, or heating operation. Star Combustion provides these items to complete a turnkey package, contact Star Combustion and see literature under a separate cover for more details.

The StarHeater requires a fuel supply with a minimum of 5 psig pressure and a maximum of 10 psig pressure. If fuel supply pressure is greater than 10 psig, the system can be supplied with an appropriately sized regulator to bring the supply pressure within range. Contact Star Combustion if the fuel supply pressure is below 3 psig. Verify the fuel supply piping size is adequate for the pressure and flow required. Contact Star Combustion Systems LLC for assistance and review of supply piping if there is question.

A drip leg must be installed in the fuel supply line prior to the gas connection on the heater in order to meet applicable fuel gas piping codes.

The StarHeater will expand in the direction of the heated air outlet when at temperature. This is most prevalent in the type HTS outlet section when near the maximum operating temperature of 1000°F, and this expansion can be up to 1". All Star|Heaters are provided with slotted mounting feet at the discharge end in order to let the heater expand as normal. The discharge end mount should not be fastened to the substrate tightly, but rather a nut should be installed hand tight, then a second nut should be tightened against the first in to keep it in place. The mounting stud should be

installed towards the front of the slot to allow movement in the discharge direction. The mounting substrate should allow the heater to move in the discharge direction, do not restrict movement of the heater legs/mounting pads. Do not use grout underneath mounting pads. See figure 1:

Figure 1: StarHeater Discharge end mounting arrangement

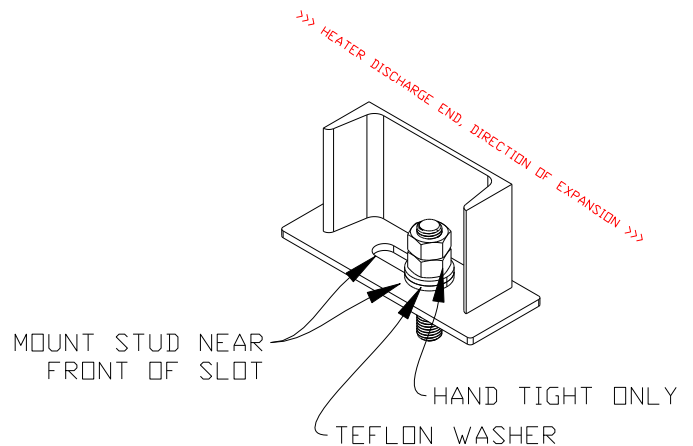

Lift the StarHeater using the lifting lugs or the designated lift points on the support frame only. Do not use a fork lift underneath the insulation skin, damage will result.

Each StarHeater comes standard with adjustable profile plates around the burner. These plates are factory adjusted for the airflow specified for the project. Prior to installation, check to verify the plates are still in the factory adjusted position and the bolts are securely in place.

Uniform airflow prior to the StarHeater is important in order to maintain proper airflow distribution around the burner and proper combustion. Non-uniform airflow can result in non-uniform temperature distribution downstream of the burner. Contact Star Combustion for a thorough review of the process air fan and ductwork to assure uniform airflow. Some things that can affect the airflow are; elbows in the ductwork prior to the burner, narrow width process air fans with impellers not installed in the middle of the fan casing. Star Combustion can provide perforated plates to be installed between the inlet flange of the heater or turning vanes in elbows to remedy non-uniform air flow prior to the burner.

STAR/HEATER INSTALLATION INSTRUCTIONS

Gaskets should be used between the flanges on the inlet and outlet of the heater. Gaskets can be supplied by Star Combustion or a 1" wide high temperature rope gasket can be used. Alternatively, high temperature RTV sealant can be used.

Every Star|Heater is rated NEMA 3R / IP56 for outdoor use, no protection from the weather is necessary. Care should be taken to prevent excessive material and debris from falling onto the StarHeater.

The ambient temperature rating of every StarHeater is -20 °F to 120 °F. Modifications can be made to the standard Star|Heater package to account for -40 °F ambient conditions, contact Star Combustion for more details.

The outlet flange of the StarHeater should be connected to a flexible connection that will allow the heater to expand up to 1" towards the discharge end of the heater. A high temperature thermal expansion joint can be designed and supplied with the StarHeater, or can be supplied by the customer.

Care should be taken when installing the Star|Heater to assure the access hatch and fuel train components remain accessible for service.

Contact Star Combustion Systems LLC at +1-513-282-0810 for questions or further information.

STAR/HEATER COMMISSIONING INSTRUCTIONS

*** IMPORTANT ***

Installation and commissioning should only be done by properly trained and qualified personnel. Failure to do so can result in significant property damage, and injury or death to personnel. Follow all applicable piping and gas safety codes when installing and commissioning this system.

Observe all appropriate safety standards when working on equipment including lockout/tagout/try and confined space entry procedures.

Once proper installation has been verified, including a burner management system with high temperature limit, process fans, temperature controls, etc, commissioning can take place. Assure the fuel supply line has been purged up to the StarHeater fuel train inlet, all system fans have been tested and are rotating in the correct direction, and that all wiring between the StarHeater and burner management system is in place and verified correct. Verify the temperature control and high temperature limit controller sensors are installed and verified working properly.

Verify fuel supply pressure at the inlet of the fuel train is between 5 and 10 psig. DO NOT ATTEMPT TO LIGHT BURNER IF FUEL SUPPLY PRESSURE IS GREATER THAN 10 PSIG, DAMAGE TO REGULATOR MAY RESULT. Contact Star Combustion Systems for further instruction if fuel supply pressure is not within range.

Verify profile plate adjustment. The profile plates around the burner are installed to create a pressure drop around the burner, forcing process air through the burner mixing plate holes. This air is used for combustion air, so it is important to keep the process air pressure drop within proper range. With all system fans started and up to appropriate speed, use a manometer across the upstream

and downstream process air pressure test points on the StarHeater to verify that the pressure drop is between 0.5"wc and 2"wc. Pressure drops below 0.5"wc can be used, but we do not recommend this as temperature uniformity downstream of the burner will be affected. Contact Star Combustion Systems for a review of ductwork design.

If pressure drop is not within the recommended range, stop all system fans, then take appropriate safety measures for a confined space entry into the heater. Remove the access hatch on the burner section to access the adjustable profile plates. Loosen the nuts securing the adjustable profile plates to the fixed profile plates, then adjust the top and bottom plates evenly (close them off if pressure drop is below the recommended range, open them up if pressure drop is above the recommended range.) It is important to keep the space between the top plate and the burner the same as that of the bottom plate and the burner. If there is significant difference, temperature non-uniformity can result. Additionally, verify that the adjustable profile plates are straight. If they are crooked, temperature non-uniformity can result.

Once the profile plates have been adjusted, tighten the nuts securing the adjustable profile plates to the fixed ones, then close the access hatch. Re-verify the pressure drop is within range after adjustment. If they are still out of range, re-adjust profile plates accordingly.

Verify process air pressure switch is adjusted to 0.4"wc minimum differential pressure. If adjusted higher, remove cover and change adjustment to 0.4"wc.

Provide initial adjustments to low and high gas pressure switches. Remove cover to low and high gas pressure switches, adjust low gas pressure switch to minimum setting, then adjust high gas pressure switch its maximum setting. These switches will be re-adjusted later, but this initial adjustment should allow for burner ignition and prevent a nuisance trip while commissioning.

STAR/HEATER COMMISSIONING INSTRUCTIONS

Provide initial adjustment to high temperature limit controller(s). Verify the high temperature limit controller(s) is/are programmed for the appropriate sensor input and that the correct sensor is connected. The limit controller should be programmed to fault when a sensor is disconnected or faulty. A sensor test should be performed to verify the appropriate sensor is connected by disconnecting the sensor wires AT THE SENSOR END, then verifying the appropriate limit controller shows a disconnected sensor on the display. The set point of the controller(s) should be determined by the customer, and is/are normally set to protect the heater and any equipment downstream of the heater. Once this set point is determined, program this into the limit controller as necessary.

Verify all system fans are interlocked with the burner management system. All system fans should be interlocked with the burner management system via a contactor auxiliary or a VFD at speed contact.

Put the burner firing rate controller in manual and verify it is at the minimum firing rate position. Adjust the valve actuator or linkages so that the main gas control valve is approximately 15% open at the minimum firing rate position. Refer to instructions for the air fuel ratio controller being used for further information on how to set this valve.

Provide initial adjustments to pilot regulator and pilot air and gas adjusting orifice. Adjust pilot gas regulator to an outlet pressure between 50"wc and 60"wc. Remove cap from pilot gas adjusting orifice, turn adjusting screw clockwise so it is all the way closed, then turn adjusting screw counter-clockwise so it is three turns open. Perform the same operation for the pilot combustion air adjusting orifice.

Verify initial adjustments to main gas regulator. Adjust main gas regulator to an outlet pressure between 2 psig and 3 psig.

Test main and blocking gas shut off valve proof of closure switches. This test should be done with the burner off, before attempting ignition for the first time. With all the manual gas valves closed, remove the main gas shut off valve actuator from the gas valve body and verify the burner management systems indicates a fault. Repeat this procedure for the blocking gas shut off valve. Contact Star Combustion for this test procedure when using Maxon brand shut off valves.

Test valve proving system, if used. Close downstream manual gas valve and attempt valve proving test, verify it indicates failure of the main gas shut off valve. Next, close upstream manual gas valve and attempt valve proving test, verify it indicates failure of the blocking gas shut off valve.

Set combustion air control valve at minimum position. Using the air fuel ratio controller, set the main combustion air control valve so the combustion air differential pressure gauge on the heater reads 0.1"wc at the minimum or lightoff position. Refer to instructions for the air fuel ratio controller being used for further information on how to set this valve.

Verify burner pilot and spark. If using a burner management control panel provided by Star Combustion Systems LLC, refer to the sequence of operation provided with that control panel for directions on how to start the burner. If burner management is not provided by Star Combustion Systems LLC, refer to the manufacturer's provided literature for instruction on how to start the burner.

Spark will not be visible from the sight port of the heater, as it is concealed within the burner.

Once spark is established, the pilot should light within 2-3 seconds. If the pilot does not light within the pilot flame establishing period (normally 10 seconds), verify the manual gas shut off valves are on, verify the pilot gas pressure is adjusted to 50-60"wc, and that the pilot air and gas adjusting orifices are 3 turns open. Also check that the pilot solenoid valves are wired correctly and are opening at the appropriate time. Further, check for loose pilot gas connections, obstructions in the pilot at the burner, and non-uniform airflow across the burner.

The pilot should be visible from the heater sight port and should be tennis ball sized. If the flame is smaller or larger than a tennis ball, adjust the pilot gas adjusting orifice accordingly.

Verify main flame. Once the pilot is established, the main gas valves should open and allow main gas to flow to the burner. Visually verify the main flame is lit all the way across the burner at low fire. The flame should look like a small zipper of flame at the base of the burner mixing plates and should not extend more than 1-2" from the burner face.

STAR/HEATER COMMISSIONING INSTRUCTIONS

If the flame is not lit all the way across or looks weak, adjust the main gas control valve open slightly. If the flame extends past the base of the burner more than 1-2", adjust the main gas control valve closed slightly.

IMPORTANT! Verify that the pilot flame is extinguished after the main flame establishing period, normally 10 seconds after the main gas valves are opened. The Star|Heater must have an interrupted pilot in order to meet applicable fuel gas codes.

With the burner ignited, re-verify the main gas regulator outlet pressure is between 2 psig and 3 psig, and adjust accordingly.

Test burner interlocks. Once the main flame is established, all burner interlocks must be tested for proper operation and set according to the applicable fuel gas code instructions. **IMPORTANT!** If there is a burner interlock failure during testing, the burner/heater should not be used until the interlock is repaired and verified working correctly. **DO NOT ATTEMPT TO BYPASS A BURNER INTERLOCK FOR ANY REASON.**

With the burner on and at minimum fire, the interlocks should shut off the burner and the appropriate alarm should be displayed on the burner management controls. Manual intervention should be necessary to re-start the burner after an interlock failure.

- ◇ Test the high temperature limit controller(s) by bringing the set point below actual. The final set point of the controller(s) should be determined by the customer, and is/are normally set to protect the heater and any process equipment downstream of the heater.
- ◇ Test the low gas pressure switch by bringing the set point below actual. The final setting of this switch should be determined by local fuel gas codes, normally 50% below the lowest manifold pressure measured at the switch (normally seen at high fire.)
- ◇ Test the high gas pressure switch by bringing the set point above actual. The final setting of this switch should be determined by local fuel gas codes, normally 50% above the highest manifold pressure measured at the switch (normally seen at low fire.)
- ◇ Test the process air pressure switch by disconnecting the upstream sensing port. The final setting of this

switch should be 0.4"wc.

- ◇ Test the combustion air pressure switch by disconnecting the upstream sensing port. The final setting of this switch should be 50% below the lowest air manifold pressure measured at the switch (normally seen at high fire.)
- ◇ Test exhaust and other air pressure switches by bringing the set point below actual or disconnecting the sensing port(s). Final settings of these switches should be determined by the local fuel gas codes, normally 50% below the lowest pressure measured at the switch.
- ◇ Test the flame sensor by shutting off the manual gas valve in the main fuel downstream of the shut off valves when the burner is ignited.
- ◇ Test the low position switch by bringing the control valve or actuator to a higher setting than the switch and attempting to ignite the burner. **IMPORTANT!** Close the pilot manual gas valve before attempting this test to prevent un-intended ignition.

Set air and gas pressures at index positions. Once the burner has been ignited and all interlocks tested and verified working correctly, verify the system can handle additional temperature and heat load. **IMPORTANT!** Verify that the high temperature limit is protecting downstream equipment from unintended heating during commissioning. Some product load inside the process equipment may be necessary to absorb the heat and allow proper high fire gas adjustments.

Use the differential pressure gauges mounted to the heater or a manometer to measure differential combustion air and gas pressure between the combustion air pressure test connection and the downstream heater pressure connections, as well as the gas pressure test connection and the downstream heater pressure connection.

Use the charts on page 18 to set combustion air and gas pressures according to each air fuel ratio controller index position. Refer to instructions for the air fuel ratio controller being used for further information on how to make these settings.

STAR/HEATER COMMISSIONING INSTRUCTIONS

Once the differential pressures have been set at all firing rates, re-attached the actuator linkage, or place the air fuel ratio controller into automatic mode and verify proposer burner firing rate control. The heater is now ready for operation.

Once the heater and system reach full operating temperature/capacity, verify the heater can properly expand in the direction of the outlet, adjust the mounting bolts as necessary.

AIR/FUEL RATIO SETTING FOR 2,000,000 BTU/HR PER FOOT OF BURNER CAPACITY

Air/Fuel Ratio Controller Position Index	Burner Capacity (btu/hr per foot)	Calculated Gas Flow (scfh)	Gas Press Setting ("wc)	Gas Valve Position (deg)	Desired Air Fuel Ratio (X:1)	Calculated Air Flow (scfh)	Calculated Air Flow (scfm)	Air Press Setting ("wc)	Air Valve Position (deg)
1	100,000	100	0.1		20.0	2,000	33	0.04	
2	320,000	320	0.8		16.5	5,280	88	0.3	
3	540,000	540	2.1		15.0	8,100	135	0.6	
4	760,000	760	4.2		15.0	11,400	190	1.2	
5	980,000	980	7.1		15.0	14,700	245	2.0	
6	1,200,000	1200	10.6		15.0	18,000	300	3.0	
7	1,420,000	1420	14.8		15.0	21,300	355	4.2	
8	1,640,000	1640	19.8		15.0	24,600	410	5.6	
9	1,860,000	1860	25.4		15.0	27,900	465	7.2	
10	2,000,000	2000	29.4		15.0	30,000	500	8.3	

AIR/FUEL RATIO SETTING FOR 2,500,000 BTU/HR PER FOOT OF BURNER CAPACITY

Air/Fuel Ratio Controller Position Index	Burner Capacity (btu/hr per foot)	Calculated Gas Flow (scfh)	Gas Press Setting ("wc)	Gas Valve Position (deg)	Desired Air Fuel Ratio (X:1)	Calculated Air Flow (scfh)	Calculated Air Flow (scfm)	Air Press Setting ("wc)	Gas Valve Position (deg)
1	100,000	100	0.1		20.0	2,000	33	0.04	
2	370,000	370	1.0		16.5	6,105	102	0.3	
3	640,000	640	3.0		15.0	9,600	160	0.8	
4	910,000	910	6.1		15.0	13,650	228	1.7	
5	1,180,000	1180	10.2		15.0	17,700	295	2.9	
6	1,450,000	1450	15.5		15.0	21,750	363	4.4	
7	1,720,000	1720	21.7		15.0	25,800	430	6.1	
8	1,990,000	1990	29.1		15.0	29,850	498	8.2	
9	2,260,000	2260	37.5		15.0	33,900	565	10.6	
10	2,500,000	2500	45.9		15.0	37,500	625	13.0	

STAR/HEATER COMMISSIONING INSTRUCTIONS

Burner Capacity Per Foot vs Nat Gas Differential Pressure (2.0mm btuh/ft)

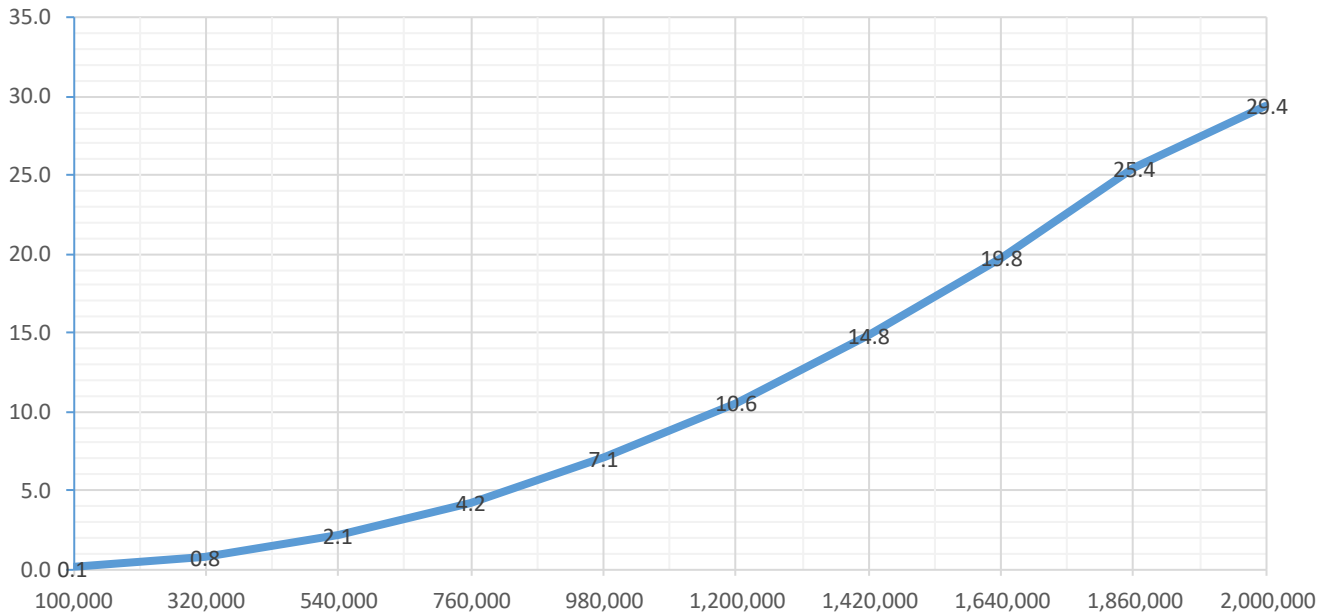

Burner Capacity Per Foot vs Nat Gas Differential Pressure (2.5mm btuh/ft)

